

Swing damper BRM10-60-01

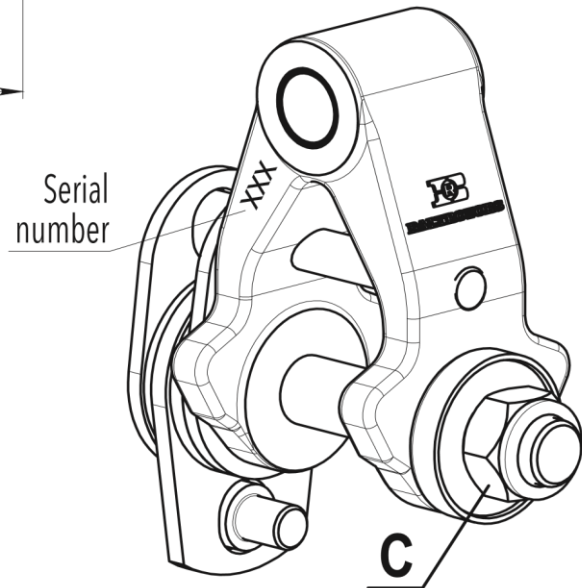
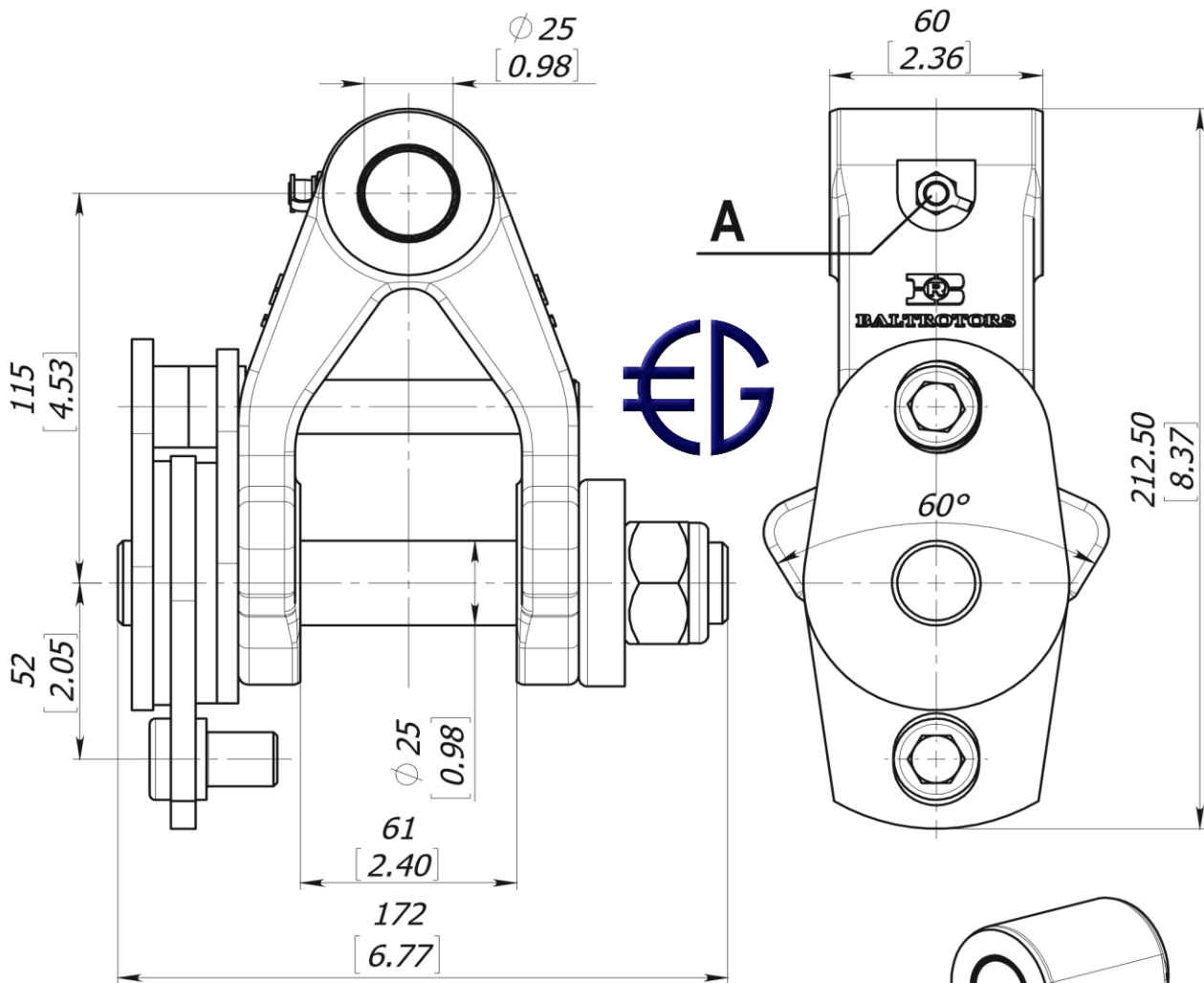

Max. Load - 3 ton (30 kN) (6744 lbf)
 Weight - 5.3 kg (11.6 lb)

13.07.2017
 Pin

locking nut (C) has to be tightened with a torque of 60-160 Nm (45-120 lb ft) dependent on desired brake power.

Fill grease Statoil Uniway Li62 (or equivalent) through lubricating nipple (A), until it will appear to the external surfaces.

Greasing must be repeated after every 8 working hours of the link.



Eurograb B.V

info@eurograb.nl

+31 (0)294208002