

Swing damper BRM10-73-01

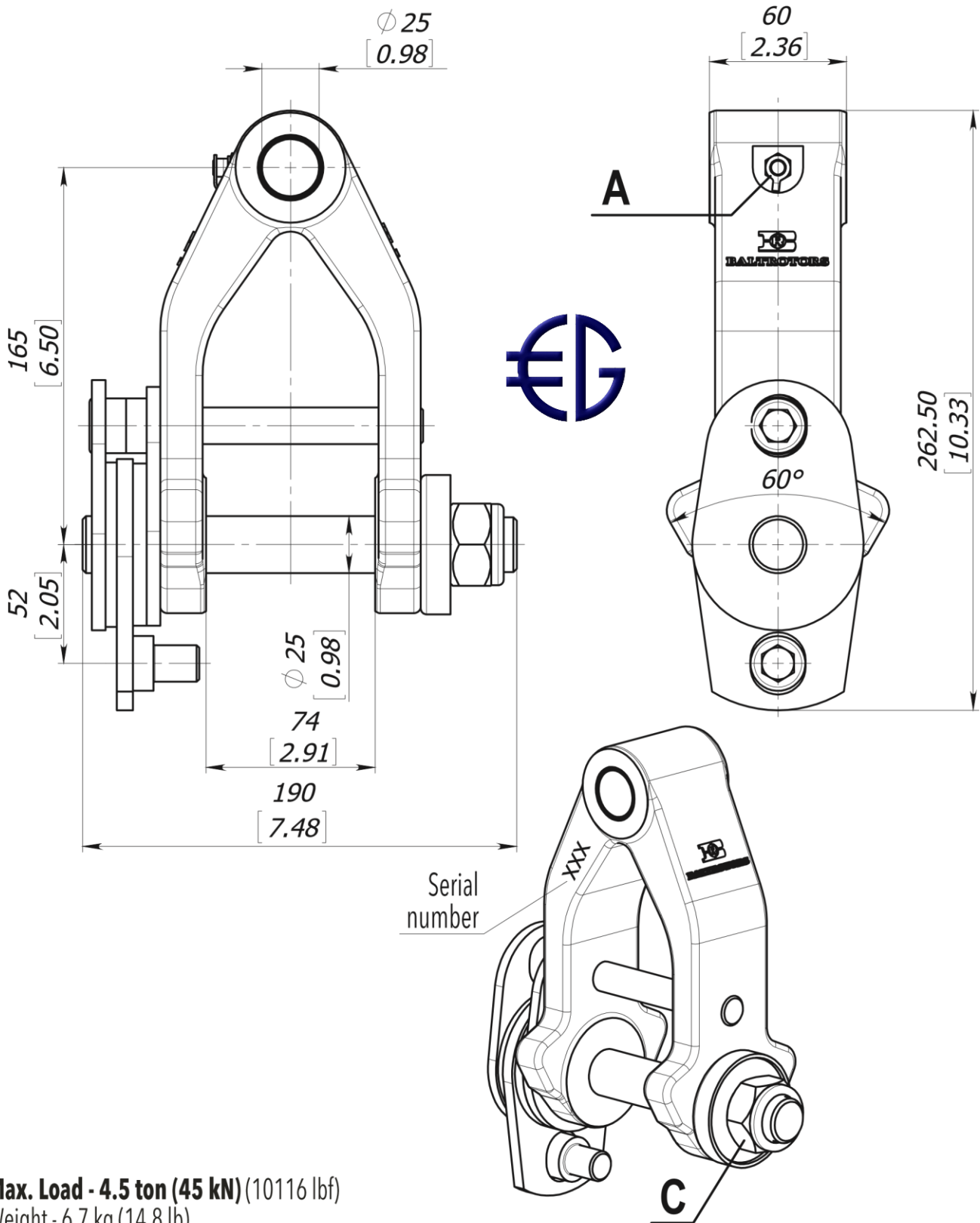

Max. Load - 4.5 ton (45 kN) (10116 lbf)

Weight - 6.7 kg (14.8 lb)

Pin locking nut (C) has to be tightened with a torque of 60-160 Nm (45-120 lb ft) dependent on desired brake power.

Fill grease Statoil Uniway Li62 (or equivalent) through lubricating nipple (A), until it will appear to the external surfaces.

Greasing must be repeated after every 8 working hours of the link.



Eurograb B.V

info@eurograb.nl

+31 (0)294208002