

LINK BR3

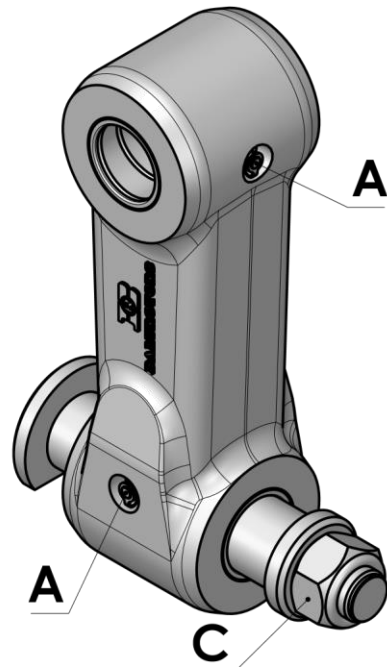
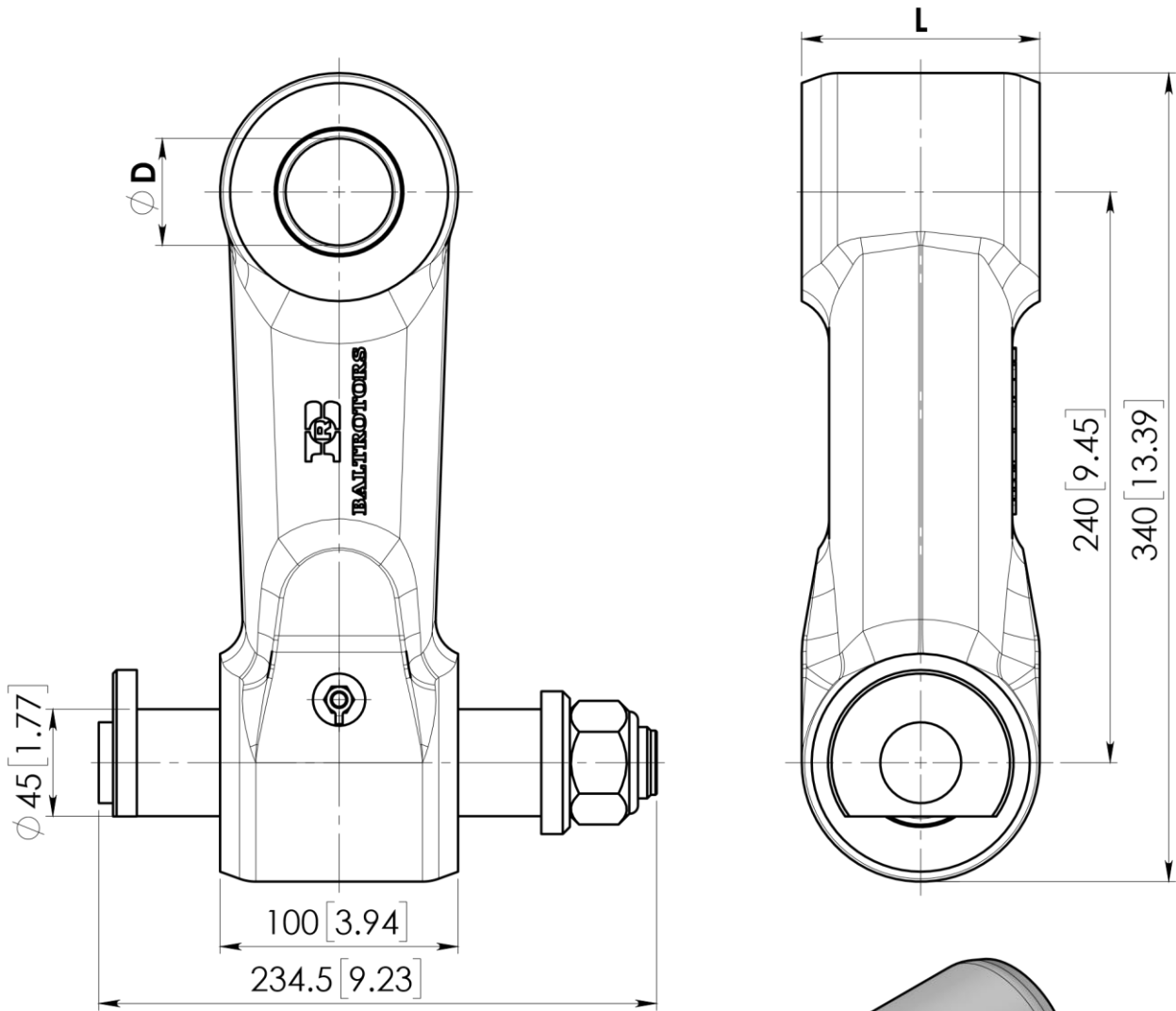

Bushing diameter [mm]:		
Upper bushing ϕD	L=100	L=80
50 [1.97"]	BR3/50	BR3-80/50
45 [1.77"]	BR3/45	BR3-80/45
40 [1.57"]	BR3/40	BR3-80/40
35 [1.38"]	BR3/35	BR3-80/35
30 [1.18"]	-	BR3-80/30
45 [1.77"]	BR3B/45*	BR3-80B/45*

*Link is assembled with bronze bushing instead of steel.

Max. Load - 16 ton (160 kN) (35976 lbf)

Weight - 21±1 kg (45.2±2.2 lb)

Pin locking nut (C) has to be tightened with a torque of 120 Nm (89 lb ft).

Fill grease Statoil Uniway Li62 (or equivalent) through lubricating nipples (A), until it will appear to the external surfaces.

Greasing must be repeated after every 8 working hours of the link.